

**INSTALLATION INSTRUCTIONS FOR
DYNOMAX TIP KIT: 88344**

2014-11 Chevrolet/GMC Silverado/Sierra 2500HD, 3500 6.6L, Diesel
2014-13 Ram 2500, 3500 6.7L Cummins Diesel



2701 N. Dettman Rd.
Jackson, MI 49201

DANGER WARNING: SHOULD THE PURCHASER DECIDE TO INSTALL ANY EXHAUST PRODUCT AT HOME, BE WARNED THAT PASSENGER CAR OR LIGHT DUTY TRUCK/VAN "BUMPER" JACKS ARE INTENDED FOR EMERGENCY USE ONLY. THE USE OF FRAME CONTACT JACK STANDS IN CONJUNCTION WITH A FLOOR JACK AS MAIN SUPPORT IS HIGHLY RECOMMENDED TO MINIMIZE ACCIDENTAL DROPPING OF A VEHICLE DURING THE INSTALLATION PROCESS.

NOTE: Read all instructions before starting any work. The following directions apply only to the 2014-11 Chevrolet/GMC Silverado/Sierra 2500HD, 3500 6.6L diesel. **See the back page for installation directions on the 2014-13 Ram 2500, 3500 6.7L Cummins Diesel.**

1. Cut the O.E. tail pipe assembly after the last bend and just before the last weld area. Cutting at this point will allow enough room to clamp the DynoMax tip extension pipe and SS tip.



2. Install DynoMax extension pipe **52487**. Use the 4" band clamp to tighten the O.E. tail pipe.
3. Install DynoMax SS tip **36483** using the 5" band clamp. Position the tip to suit appearance.
4. Beginning at the inlet end, align the extension pipe and tip and fully tighten the all clamps.

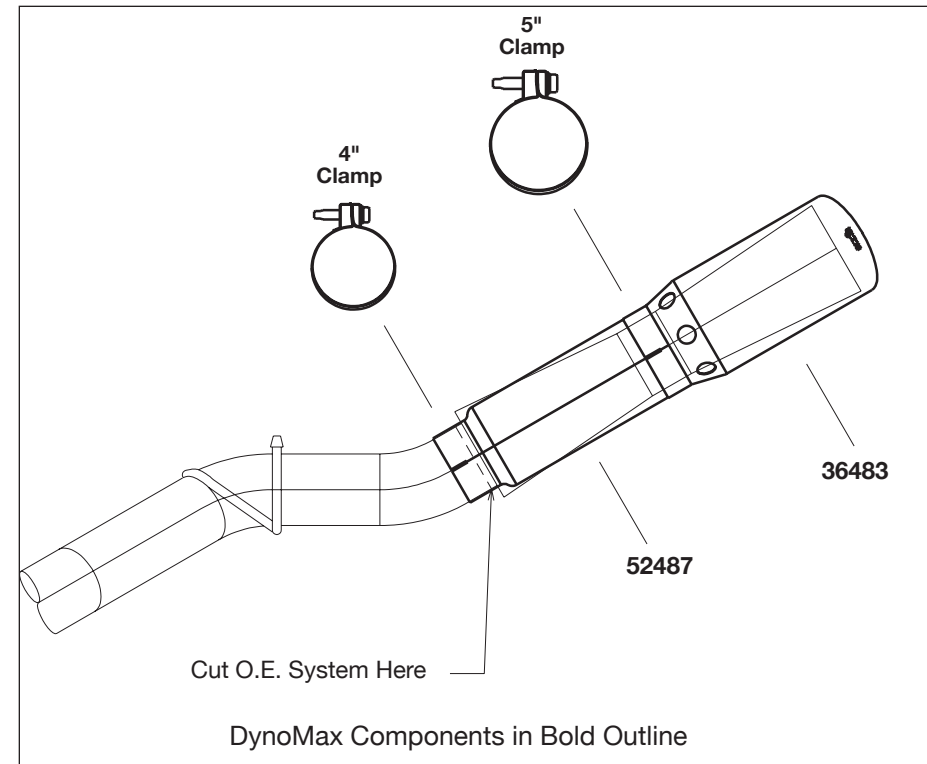

KIT CONTAINS:

- (1) 52487 EXTENSION PIPE
- (1) 36483 SS TIP
- (1) 4" BAND CLAMP
- (1) 5" BAND CLAMP (Included with tip)
- (1) INSTRUCTION SHEET

88344 SYSTEM

Follow these directions for installation on the 2014-13 Ram 2500, 3500 6.7L Cummins turbo Diesel.

1. Measuring from the tip of the tail pipe, cut 16" off the outlet end.
2. Install Dynomax extension pipe **52487**. Use the 4" band clamp to tighten to the OE tail pipe.
3. Install Dynomax SS tip **36483** using the 5" band clamp. Position the tip to suit appearance.
4. Beginning at the inlet end, align the extension pipe and tip and fully tighten both clamps.